



PLASTIC WELDING

Roofing

2019/2020



Flat- and Pitched Roofs

Everything for welding on the roof







Dear Leister customers

When working on the roof, you always need to be able to completely rely on your devices. This is our firm belief. And this is why you should quite rightly have high expectations of a Leister automatic roof welding machine: We guarantee to provide you with maximum device reliability and the best all-round service.

Our welding devices are highly reliable even in difficult conditions with undervoltage. A high level of flexibility is also required when it comes to automatic welders. Our devices are used in numerous roof applications as well as in situations where space is at a premium. With their sophisticated ergonomics, the easy-to-handle automatic roof welding machines are keeping abreast of the trend, which is moving away from manual welding and in the direction of automatic welding. Using the UNIROOF, you can carry out welding both in and on the parapet. The economic efficiency is also given to a high degree with automatic welding.

We always strive to tailor the devices to meet our customers' needs in the best way possible. Our development department is continually carrying out research into new technologies so that we can offer you the highest-possible quality. This is why you can count on Leister to provide devices that use state-of-the-art technology. Even under the harshest conditions, you can therefore rely on our automatic welders. This is what we have stood for for more than 70 years.

In this brochure, you will find numerous application options, as well as tips and tricks. These will help you to ensure a leak-free roof, whether you are using bitumen or plastic.

I hope you enjoy reading our brochure!

Roland Beeler

Business Line Plastic Fabrication, Roofing & Flooring (PRF)

For all roof applications

Whether you're working in or on the parapet, under vaults, or on flat surfaces – you are guaranteed to find the automatic welders you need among our wide range of products. Here, you will gain an overview of various roof applications and find out which automatic welders are suitable for which applications.

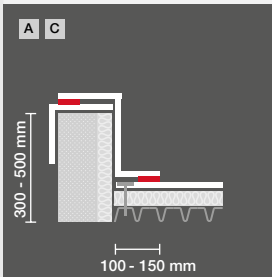

The **UNIROOF AT/ST** welds as close as 100 mm to the edge of the parapet or on the parapet without leaving a gap. Just one device for two applications. This flexibility enables a reliable jointing technique. Detail C enables anti-fall protection to be applied in a controlled and safe manner.

UNIROOF AT/ST page: 18 - 20

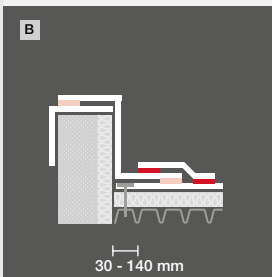

As the **UNIDRIVE 500** only requires 30 - 40 mm to insert an overlap from right to left, you can weld tirelessly in a safer environment.

UNIDRIVE 500 page: 15 - 17

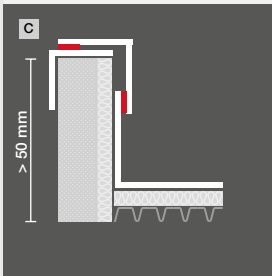

Thanks to the handles of the **UNIDRIVE 500** it allows to weld difficult details ergonomically, cleanly and tightly. Thanks to the rotating nozzle and reversible drive, all welding applications can be carried out. The UNIROOF AT/ST can also be used as an alternative.

UNIDRIVE 500 page: 15 - 17
UNIROOF AT/ST page: 18 - 20

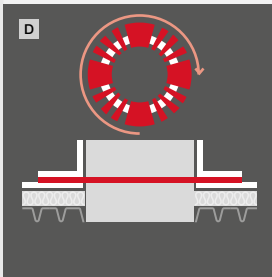

The **UNIDRIVE 500** can be used flexibly and simplifies circular welding. This semi-automatic device is suitable for detail work and closes the gap between manual and automatic welding.

UNIDRIVE 500 page: 15 - 17

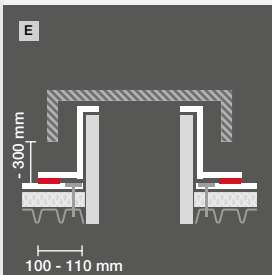

The **UNIROOF AT/ST** enables sealing sheets to be used even on a wide range of details, such as domed skylights, special balustrades, or renovations. This is made possible by its compact design and height, which does not exceed 300 mm.

UNIROOF AT/ST page: 18 - 20

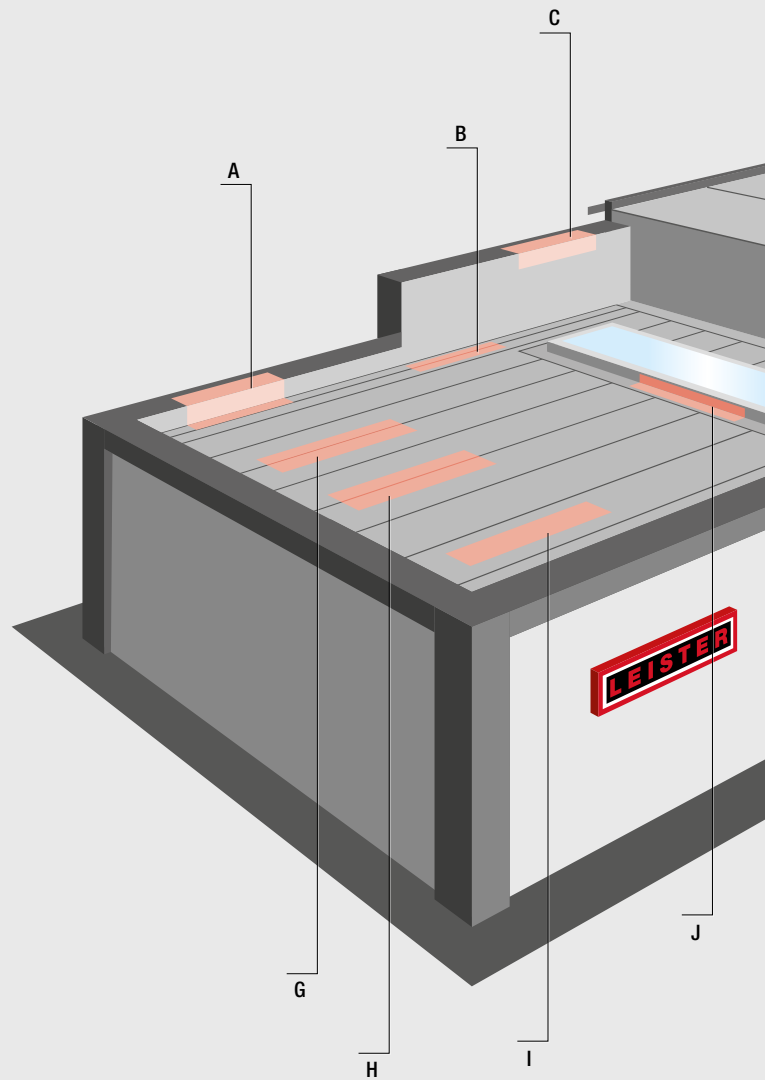

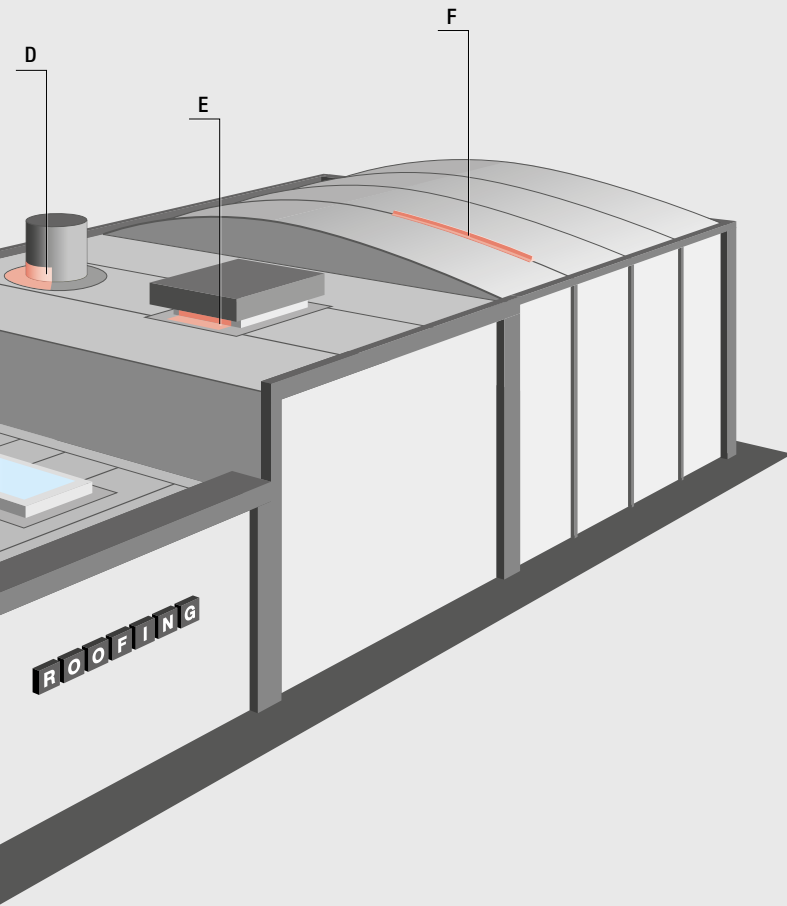

Arduous manual welding is a thing of the past. You can weld safely and ergonomically with the **UNIROOF AT/ST 155.414 kit for plastic roof profiles**. You can set the pressure rollers steplessly according to the width of the profile. At 2 m/min, you can carry out welding extremely efficiently.

UNIROOF AT/ST 155.414 kit Page: 20

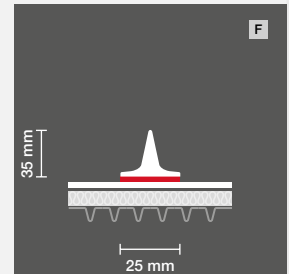

The popular, ergonomic **VARIMAT V2** automatic roof welder welds all TPO and PVC sealing sheets with extra pressure thanks to its patented pressure roller and trailing roller. Its high blowing capacity guarantees high efficiency for all sealing sheets. This is also possible with the UNIROOF AT/ST.

UNIROOF AT/ST page: 18 - 20
VARIMAT V2 page: 22 / 23

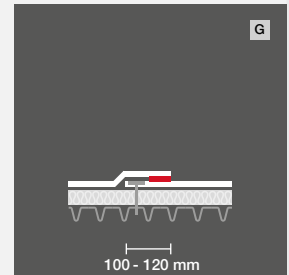

Sealing tape is welded over when fastening rails are used. Using the **UNIROOF AT/ST**, you will achieve a reliable weld in two sequences. This is also possible with the VARIMAT V2.

UNIROOF AT/ST page: 18 - 20
VARIMAT V2 page: 22 / 23

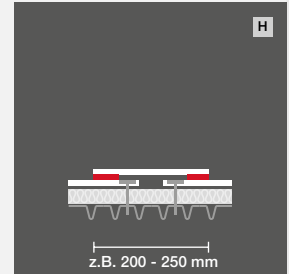

Sealing tape of between 200 and 250 mm is welded over when fastening rails are used. Using the **UNIROOF AT/ST** and VARIMAT V2, you will achieve a reliable weld in two sequences.

UNIROOF AT/ST page: 18 - 20
VARIMAT V2 page: 22 / 23

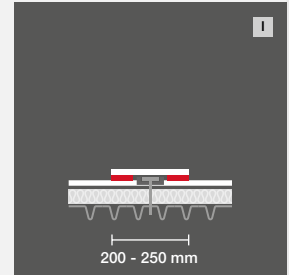

The **VARIMAT V2 mirror kit** enables you to weld as close as 60 mm to the edge. The saves materials and is economical. The mirror-inverted nozzle is also suitable for numerous other applications.

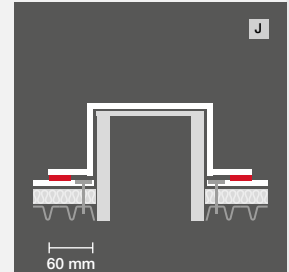

Mirror kit for VARIMAT V2 page: 23







The benefits of Leister at a glance:

Robust device components

-  Low service costs with maintenance-free brushless drive and blower motors
-  Durable heating elements
-  Corrosion-resistant weights

Performance

-  High welding speeds and top performance
-  Automatic welders with maximum flexibility cuts out steps in the process
-  Low failure rates at the construction site (even with a generator)

Service

-  Support and device demonstration by our field service representatives
-  Everything available from a single source thanks to a wide product range
-  Tight distribution network with short delivery times
-  Welding window service
-  Long spare parts guarantee when discontinued after 7 years
-  Quick repair and service
-  We offer the option to rental welding equipment



Aldi logistics center 50000m2 TPO Membrane, Switzerland



Exploration Place First, Wichita, USA



Schöni transport Centre, Switzerland

Roofing

Roofing welders and hot air Tools overview	8 / 9
Tips and Tricks	10 – 14
UNIDRIVE 500	16 / 17
UNIROOF AT / ST	18 – 20
VARIMAT V2 / VARIMAT S	22 / 23
BITUMAT B2	24
EXAMO USB / Testing instrument	25

Hot Air Tools for Roofing





TRIAC ST	26 – 28
TRIAC AT	27 / 28
ELECTRON ST	30 / 31
HOT JET S	32
General accessories	33



Detail work on the rooflight dome.







Flameless welding of modified bitumen with the BITUMAT. B2.

Overview Roofing Welders				
Materials	Thermoplastic Single-Ply membranes			Modified Bitumen
Type of welding machine	UNIDRIVE 500	UNIROOF AT/ST	VARIMAT V2 / VARIMAT S	BITUMAT B2
Main application	Parapets, tight spaces, pitched roofs	Parapets, edges Residential construction surfaces under 500 m2	Welding close to edges Industrial surfaces over 500 m2	First bitumen layer
Roof construction				
Flat roof	✓✓✓	✓✓✓	✓✓✓	✓✓✓
Sloped roof	✓✓✓	✓✓	✓	✓
Basic weld seams	✓	✓✓	✓✓✓	✓✓✓
Detail work	✓✓✓	✓✓✓	✓	✓
Thickness of sealing sheets	up to 1.8 mm	up to 1.8 mm	up to 2 mm / 1.8 mm	up to 6 mm
Special features	Welding on both sides with rotating nozzle	Ideal for roof edge welding	Double welding performance against competitors	Flameless welding
Parapet spacing in mm	45	100	110	200
Generator operation	4KW	At least 6 kW to supply a hot air hand tool	At least 10 kW to supply a hot air hand tool	
Electronics				
Regulated for drive and heater (closed-loop system)	UNIDRIVE 500	UNIROOF AT	VARIMAT V2	
Controlled for drive and heater (open loop)		UNIROOF ST	VARIMAT S	BITUMAT B2
Speed m/min.				
Drive	0.7 – 4.5	1 – 10	0.7 – 12	0.8 – 12
Welding speed (depending on material)	1 – 2.5	2 – 3	4 – 8	3 – 6
Recommended welding start parameter depending type of membrane (tested by room condition 20°C)	PVC membrane: 2.0 m/min, 480 – 520°C, air volume 100% TPO/FPO membrane: 2.0 m/min, 420 – 470°C, air volume 100%	UNIROOF AT PVC: 2.0 m/min, 520°C, air volume 100% TPO: 2.5 m/min, 450°C, air volume 100% UNIROOF ST PVC: 1.8 m/min, 520°C, air volume 100% TPO: 2.0 m/min, 450°C, air volume 100%	VARIMAT V 2 PVC: 4.0 m/min, 550°C, air volume 85% TPO: 5.0 m/min., 500°C, air volume 100% VARIMAT S: PVC: Temperature level 8.5–9 (550°C) TPO: No trailing roller, can only be used to limited degree	nozzle till 100 mm Modified Bitumen: 5.0 m/min, 650°C, air volume 100%
Weight kg	4.5	17.5	35 / 28	40
Blower technology	Brushless	Brushless	Brushless / Brush motor	Brush motor
Catalog page	 16 / 17	18 – 20	22 / 23	24

✓✓✓ = Highly suitable, ✓✓ = Suitable, ✓ = Limited suitability



Manual welding with plastic sealing sheets.

Overview Hot-air hand tools				
Typ	TRIAC ST	TRIAC AT	ELECTRON ST	HOT JET S
Area of application	Joining of thermoplastic sealing sheets with high welding power	Joining of thermoplastic sealing sheets with high welding power	Joining of modified bitumen	Joining of thermoplastic sealing sheets in tight spaces. For detail work on roof gutters and parapets, for example
Starting welding parameters manual weld	PVC: From 360 C TPO: From 295 C	PVC: From 360 C TPO: From 295 C	Modified bitumen: From 550 C	PVC: From 360 C TPO: From 295 C with 20 mm nozzle
Sealing sheets	Suitable for PVC/TPO sealing sheets with wide welding window	Suitable for PVC sealing sheets with wide welding window and TPO with narrow welding window	Modified bitumen	Suitable for PVC/TPO sealing sheets with narrow welding window
Electronic	Open loop	Close loop	Open loop	Open loop
Catalog page	 26 – 28	27 / 28	30 / 31	32

Closed-loop system

The closed-loop technology means that the parameters are kept constant at all times, even in the event of voltage fluctuations, enabling reliable welding in the building site environment.

Closed loop System

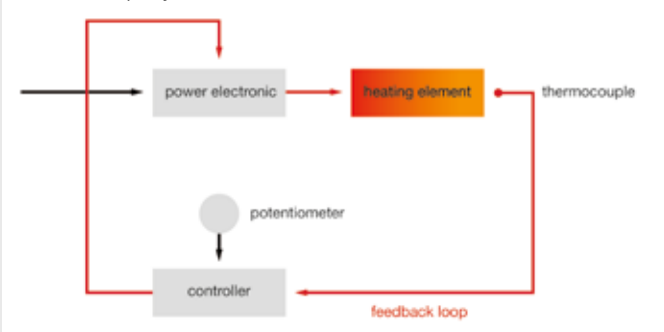

Open loop System

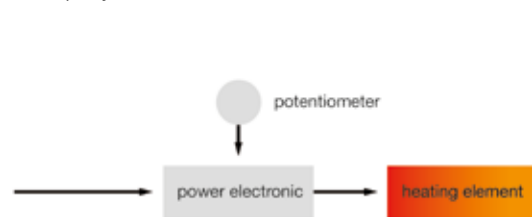

Leister. We know how. - Tips and tricks

Leister Technologies AG offers high-quality welding devices for demanding tasks – in any industry where plastic is processed.

Here you can find a few tips and tricks that will help you ensure that your roof is leak-tight, whether the work involves bitumen or plastic.

Know-how

Welding Methods

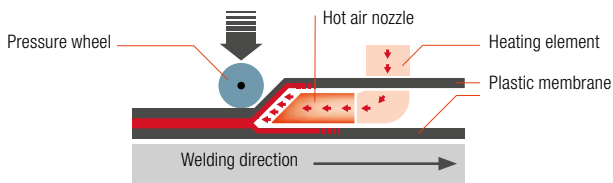

Hot-air welding

Hand tools, automatic welders, stationary welding machines

In hot gas welding, the thermal energy is controlled. Heated air is fed into the workpiece and the required amount of pressure is exerted onto the wheels.

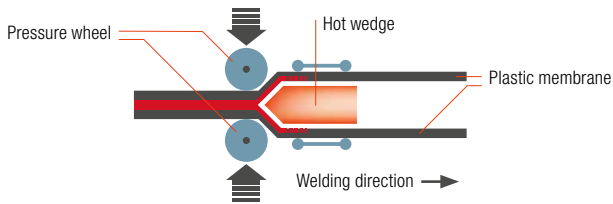

Hot-wedge welding

Wedge welders

The process where the wedge is heated directly by heating cartridges. The generated heat is transferred directly onto the workpiece. This method also is suitable for thicker materials.

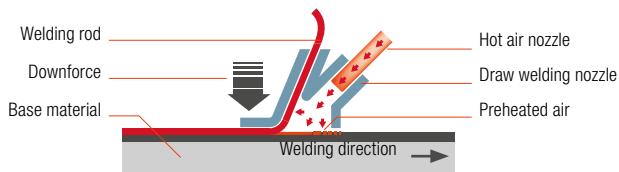

Draw Welding (Speed Welding)

Hand tools

This welding method requires the use of a speed welding nozzle. Preheat the surfaces to the appropriate temperature. The surfaces are plasticized by hot air and joined under consistent downward pressure.

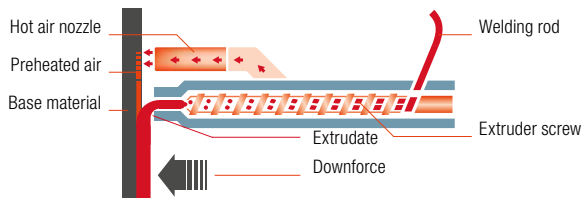

Extrusion Welding

Extrusion Welders (FUSION & WELDPLAST)

In extrusion welding, the substrate is preheated with hot air and connected by adding the extrudate. The welding rod is fed into the heater barrel and the plast is processed by the extruder screw.

Weld Types / Weld Geometries

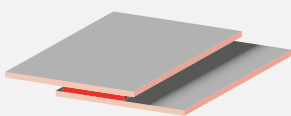

Overlap

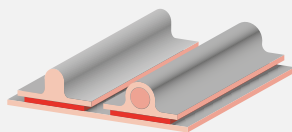

Antivandalism

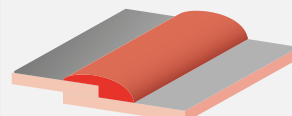





Overlap seam



Air partitioning keeps the hot air in the weld seam to ensure reliable welding.





Know-how

Basic automatic welding machine equipment

	<p>132.429 Welding plates for optimum welding start and end</p>		<p>116.798 Brass brush UNIROOF AT/ST and VARIMAT V2 151.847 Brass brush UNIDRIVE 500</p>
	<p>151.382 Kehlfix</p>		<p>137.855 Leister cutter 138.902 Hooked blade for LEISTER-cutter (10 dispenser with 10 pcs) 138.539 Straight-edge blade for LEISTER-cutter (10 dispenser with 10 pcs)</p>
	<p>106.972 Brass pressure roller with ball bearings</p>		

Caution! Always carry out test welds before starting lap welds. In the morning and in the afternoon

Basic hot-air hand tool equipment

	<p>107.132 Wide slot nozzle 40 mm 107.123 20 mm Wide slot nozzle angled</p>		<p>157.544 Leister foil scissors</p>
	<p>107.124 20 mm angled nozzle, 90° 105.503 20 mm angled nozzle, 60° / 105°</p>		<p>138.314 Seam probe tester for overlap seams</p>
	<p>silicone pressure roller 140.160 40 mm 140.161 20 mm 106.976 Pressure roller PTFE</p>		

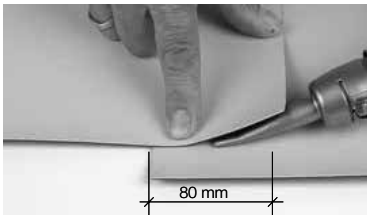

1. Stitching the overlap

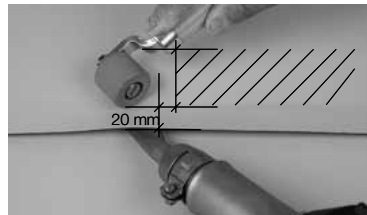

2. Pre-welding

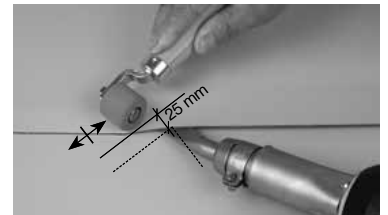

3. Final welding

Know-how

Correct hot-air welding

- Rule no. 1: weld like with like
- In all welding processes, ensure the correct temperature/pressure/speed settings are made so that seams can be created without problems. The joining surfaces must be dry and free from contamination.
- Always check the hot-air welding device (for blocked nozzles, for defective heating elements, and in case the filter requires cleaning)
- Carry out test welding and check seams for peeling
- In the case of homogeneous sealing sheets, elastic bands may be used as welding aids.

Avoiding air inclusions

In the case of hard, uneven substrates (PIR/PUR with aluminum cladding) or mineral fiber insulation in combination with PVC sealing sheets, it is important to avoid air inclusions. You can prevent them by using a softer pressure roller together with a rake nozzle kit for the VARIMAT V2 automatic welding machine (see page 13).

Manual welding process

The hot-air nozzle should be cleaned periodically to prevent contamination getting into the weld seam and to ensure that welding is able to take place at full power. The distance between the pressure roller and the nozzle opening should be between 20 and 30 mm to ensure that the weld seam is joined as efficiently as possible. The pressure roller must be guided so that it is parallel to the nozzle. This will ensure that the welding process yields the best possible results (see images above).

Welding under building site conditions

Substrate properties

- Solid substrate with fine surface, no elevation (clean laying)
- The building ground should be free from pointed objects and stones.

Environmental conditions/Weather conditions/Rain

If it is raining, welding must not be carried out without special protective equipment.

Air temperature

Welding must be suspended at temperatures below +5°C in or-

der to prevent the roof sheeting being exposed to an excessively high thermal load (in accordance with DVS 2225-4).

Humidity

In some cases, excessively high humidity can cause condensation to form on the welding surface, which has a negative effect on the seam strength.

Wind

If there is strong wind, the required welding temperature may not be reached in some cases. This can be counteracted by raising the welding temperature by 20 to 30°C or reducing the speed by 20 to 40 cm/min. If the wind is excessively strong, the welding area should be shielded against wind or welding should be suspended.

Sun

Exposure to the sun will cause materials to heat up significantly, particularly black sealing sheets. The sheet will experience increased thermal expansion if this happens. This causes wrinkles, which makes the welding process more difficult and leads to an inadmissibly high level of tension in the seam area when the material cools.

Maintaining the hand tool

- The air inlet and filter must be cleaned periodically.
- The heating element should be cleaned periodically.



This will ensure that the right level of welding power is reached.

Defining the generator power

The generators must have the correct specifications in order to ensure safe operation:

- VARIMAT V2: Min. 10 KW to ensure a reserve for hand tools
- UNIROOF AT/ST: Min. 6 KW

Adjusting nozzles for UNIROOF AT/ST and VARIMAT V2/S

- Distance between middle of spherical roller to tip of nozzle: 42 mm
- Position standard nozzle at a slight angle; approx. 1 mm (sketch C)
- Grip nozzle must lie flat

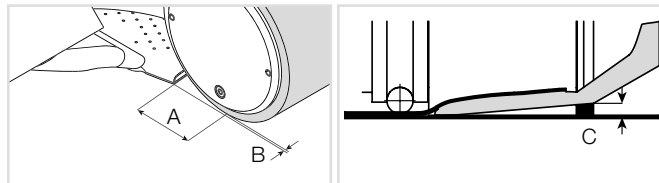

A = 42 mm +/-2
B = 1-2 mm

C = 1 mm

Know-how

What to note in the case of air inclusions.

Rake nozzle kit to solve the problems caused by bubbles forming on hard surfaces.

Growing heat insulation requirements have caused roof structures to undergo changes in recent years. Additionally, hard PIR/PUR or thicker mineral wool insulating materials with a higher level of compressive strength are now installed on the upper side. During the welding process, these insulating materials demonstrate virtually no temporary elastic behavior. These properties may cause air inclusions to arise in the weld seam of mechanically fastened PVC roof sealing sheets under certain climatic or local conditions. The new rake nozzle kit ensures that all leak-tightness and aesthetic requirements are met even in roof structures of this nature.

Rake nozzle:

Continuous and constant weld seam width. To prevent air inclusions, the lower PVC roof sealing sheet is pressed down using the rake nozzle.

Pressure roller:

The soft silicone pressure roller enables the pressure to be distributed as effectively as possible over uneven and hard substrates.



Use the right extension cables!

Voltage drop due to cable length

Important facts

- The cable should be copper, with as large a cross-section as possible
- The cable should be as short as possible
- The following rules of thumb apply:
Automatic welding machines: maximum 50 m with 2.5 mm² cable, e.g., VARIMAT V2 4.6 KW 230 V/over 50 m 4.0 mm² Manual welding: maximum 50 m with 1.5 mm² cable, e.g., TRIAC AT/ST 1.6 KW 230 V
- Plug for 20 amps and a secure connection
- A generator should have a capacity of 10 KW
- A stable electrical environment is required
- The fuse should have 20 amps for 230 volts and 16 amps for 400 volts

Copper cable	Varimat V2 230 V / 4600 W			Varimat V2 400 V / 5700 W		
	1.0 mm ²	1.5 mm ²	2.5 mm ²	1.0 mm ²	1.5 mm ²	2.5 mm ²
50 m	200 V (-13%)	209 V (-9%)	217 V (-6%)	377 V (-6%)	384 V (-4%)	390 V (-2.5%)
100 m	177 V (-23%)	192 V (-17%)	205 V (-11%)	256 V (-11%)	370 V (-8%)	381 V (-5%)
150 m	159 V (-31%)	177 V (-23%)	194 V (-16%)	338 V (-16%)	356 V (-11%)	372 V (-7%)
200 m	144 V (-37%)	164 V (-28%)	184 V (-20%)	321 V (-20%)	344 V (-14%)	363 V (-9%)
250 m	132 V (-43%)	154 V (-33%)	176 V (-24%)	306 V (-23%)	332 V (-17%)	355 V (-11%)
300 m	121 V (-47%)	144 V (-37%)	168 V (-27%)	292 V (-27%)	321 V (-20%)	347 V (-13%)
350 m	112 V (-51%)	136 V (-41%)	160 V (-30%)	280 V (-30%)	311 V (-22%)	340 V (-15%)
400 m	105 V (-54%)	128 V (-44%)	154 V (-33%)	268 V (-33%)	301 V (-25%)	332 V (-17%)
450 m	98 V (-57%)	121 V (-47%)	148 V (-36%)	258 V (-36%)	292 V (-27%)	326 V (-19%)
500 m	92 V (-60%)	115 V (-50%)	142 V (-38%)	248 V (-38%)	284 V (-29%)	319 V (-20%)
550 m	87 V (-62%)	110 V (-52%)	137 V (-41%)	239 V (-40%)	276 V (-31%)	312 V (-22%)

Know-how

Comparison: bitumen roof vs. plastic roof

STRUCTURE	WARM ROOF, BITUMINOUS, no slope	WARM ROOF, PLASTIC, sealing sheets without slope
	1 Extensive roof greening (can be walked on to a limited extent) 100 mm	Extensive roof greening (can be walked on to a limited extent) 100 mm
	2 Drain protection mat 20–30 mm 20 mm	Drain protection mat 20–30 mm 20 mm
	3 Bitumen sheets, 2-layer, EGV 3.5/EP5WF (root-resistant) 10 mm	Plastic sealing sheet 2 mm
	4 PU ALU 240 mm U value 0.10 (W/(m ² x K)) 240 mm	PU ALU 240 mm U value 0.10 (W/(m ² x K)) 240 mm
	5 Vapor barrier EVA 35 5 mm	Vapor barrier EVA 35 5 mm
	6 Concrete ceiling without slope 240 mm	Concrete ceiling without slope 240 mm
EVALUATION		
Safety	<ul style="list-style-type: none"> - Black sealing sheets cannot be identified - Sealing installed using flame and gas (working hygiene, fire hazard) + Layer thickness of approx. 9 mm (mechanical damage) - Bitumen is not generally root-resistant (only if herbicides are used, and these are washed out over time and enter groundwater). + Service life approx. 40 years 	<ul style="list-style-type: none"> + Plastic sealing sheets are marked and can be identified even after 50 years + Installed using automatic welding machine (homogeneous welding) - Sealing 1.8 mm, relatively thin but higher dielectric strength + Plastic sealing sheets are root-resistant throughout their entire service life; no need for critical additives, etc. + Clean installation without dirt + Service life 55 to more than 100 years
Ecology	<ul style="list-style-type: none"> - Dismantling, disposal in municipal solid waste incineration plant - Significant impact on the environment (compare environmental impact points calculation enclosure) - Root resistance only incorporated with the use of herbicides - 6x higher fire load, weight/content by mass approx. 12 kg/m² - Mass with 5,545 m² = approx. 66 to 	<ul style="list-style-type: none"> + TPO sealing sheets sorted according to category can be recycled + TPO sheets have a low impact on the environment and have the highest recommendation according to ECO (112 million environmental impact points; less than bitumen at 3,650 m²) + Root-resistant without herbicides + Weight/content by mass approx. 2 kg/m² + Mass with 5,545 m² = approx. 11 to; i.e., a total of 55 to less weight with the plastic sealing sheet!
Logistics	<ul style="list-style-type: none"> - 5,545 m²: 60 pallets more of material = more crane trains required 	<ul style="list-style-type: none"> + 5,545 m²: total area with 10 pallets
Costs	<ul style="list-style-type: none"> + Cost-neutral 	<ul style="list-style-type: none"> + Cost-neutral/the larger the industrial roof, the less expensive
Warranty	<ul style="list-style-type: none"> + 10-year system warranty 	<ul style="list-style-type: none"> + 10 to 15-year full material warranty (for the entire system)
Installation performance	<ul style="list-style-type: none"> - More time required due to 2-layer installation, 10x1 m/8x1 m 	<ul style="list-style-type: none"> + Length of sealing sheets can be adjusted; faster installation, less impact on sheets = safer

Summary: The plastic sealing sheet is the better option, depending on the design of the industrial roof and the permeation properties. As a result, plastic sealing sheets are set to gain a larger share of the market. Leister has the right solution for all sealing sheets.



Reliable and cost-effective – everywhere – UNIDRIVE 500

The compact UNIDRIVE 500 semi-automatic hot-air welder impresses with its many advantages. Guided by two ergonomic handles, you can achieve the ideal pressure to ensure high-quality welding results. Change welding direction with ease via a rotating nozzle and reversible drive. The UNIDRIVE 500 is ideal for all roof applications, even in tight spaces, and welds two to three times faster than manual welding. Lap welding with the UNIDRIVE 500 – reliable and cost-effective – everywhere.

Semi-automatic hot-air welder

UNIDRIVE 500



Reliable:
Ergonomic handle for balanced pressure during manual welding



Safe:
Constant parameters and reliable quality – even with undervoltage



Flexible: Stainless steel nozzle for all welding application



Customized: Reversible drive allows for welding in either direction





Whether on or at the roof parapet or welding domed skylights, connections, or small terraces – the UNIDRIVE 500 shows its worth when space is tight.

Semi-automatic hot-air welder

UNIDRIVE 500



- **Safe:** Constant parameters and reliable quality – even with undervoltage
- **Fast:** Up to three times faster than manual welding
- **Customized:** Reversible drive allows for welding in either direction
- **Practical:** Compact and lightweight semi-automatic hot-air welder: 4.5 kg, 30 cm high
- **Economical:** Maintenance-free, brushless motors

Technical data		UNIDRIVE 500 100 V	UNIDRIVE 500 100 – 120 V	UNIDRIVE 500 220 – 240 V
Voltage	V~	100	120	230
Power	W	1500	1800	2200
Temperature	°C	100 – 560		
Air volume	%	45 – 100		
Speed	m/min	0.7 – 4.5		
Emission	L _{pA} (dB)	70 (K = 3 dB)		
Size (L × H × B)	mm	297 × 173 × 275		
Weight	kg	4.5		
Conformity mark		CE		
Protection class I		⊕		

Article No.:

- 163.144 UNIDRIVE 500, 40 mm, 220 – 240 V/2200 W, Euro plug, Silicone rollers
 - 163.146 UNIDRIVE 500, 40 mm, 220 – 240 V/2200 W, CEE 3 pol. blue, Silicone rollers
 - 163.148 UNIDRIVE 500, 40 mm, 100 – 120 V/1800 W, UK plug, Silicone rollers
 - 163.149 UNIDRIVE 500, 40 mm, 100 V/1500 W, JP plug, Silicone rollers
 - 163.150 UNIDRIVE 500, 30 mm, 220 – 240 V/2200 W, EU plug, Silicone rollers
 - 163.151 UNIDRIVE 500, 40 mm, 220 – 240 V/2200 W, CEE 3 pol. blue, Steel rollers
 - 163.152 UNIDRIVE 500, 15 mm, 220 – 240 V/2200 W, CEE 3 pol. blue, Steel rollers
- Included with purchase: Welding machine, device case, hex key, quick guide

Accessories UNIDRIVE 500

	Overlap welding nozzle 164.586 15 mm 164.576 30 mm 164.403 40 mm
	163.930 Pressure roller, steel 15 mm
	163.357 Pressure roller steel 40 mm
	162.551 Support wheel, silicone
	161.156 Silicone rubber roller 40 mm
	159.911 Wheel for silicon rubber roller 40 mm
	151.847 Brass brush
	164.605 Storage case UNIDRIVE 500 156.531 Carrying strap for Leister case
	145.582 Heating elements 230 V / 2200 W 165.176 Heating elements 120 V / 2100 W 165.179 Heating elements 100 V / 1600 W

UNIROOF AT/ST: Welding close to the edge made easy.

The new UNIROOF AT/ST roof welder is your flexible partner for welding thermoplastic roofing membranes on flat or pitched roofs (up to 30°). Thanks to its slim design and construction, as well as the movable transport axle, converting of the machine is no longer needed. Now, you can effortlessly weld close to the edge (to 100 mm) at the parapet or on the parapet and as easily in narrow circumstances.

Hot-air welder

UNIROOF AT/ST



No more time consuming converting: The ultra slim roof welding machine with its movable transport axle masters welding close to the edge (up to 100 mm) at or on the parapet, and wherever it gets narrow.



UNIROOF provides elaborate ergonomic handling thanks to steering bar and handle: Roll or carry the UNIROOF whenever, wherever you want to, it's so handy!



UNIROOF AT: The **closed-loop technology** for drive motor, temperature and air blower keeps the welding parameters at a constant level and thus delivers reliably leak proof results – a clear asset when it comes to process reliability and investment safety.



UNIROOF AT: Functional **control panel with display** for welding parameters (set point and actual figures during runtime) as well as voltage for better control. Save time with programmable welding profiles for common roof membranes.



UNIROOF ST for purists: **Closed-loop** controlled drive motor with **open-loop technology** for the control of temperature and air blower. Simple control (regulation) with potentiometer/rotary knobs.



Optimum overall performance and easy-to-operate: The direct-driven, maintenance-free pressure wheel [brushless drive motor integrated in pressure wheel] leads to higher contact pressure, welding speed and thus causes zero chain wear.

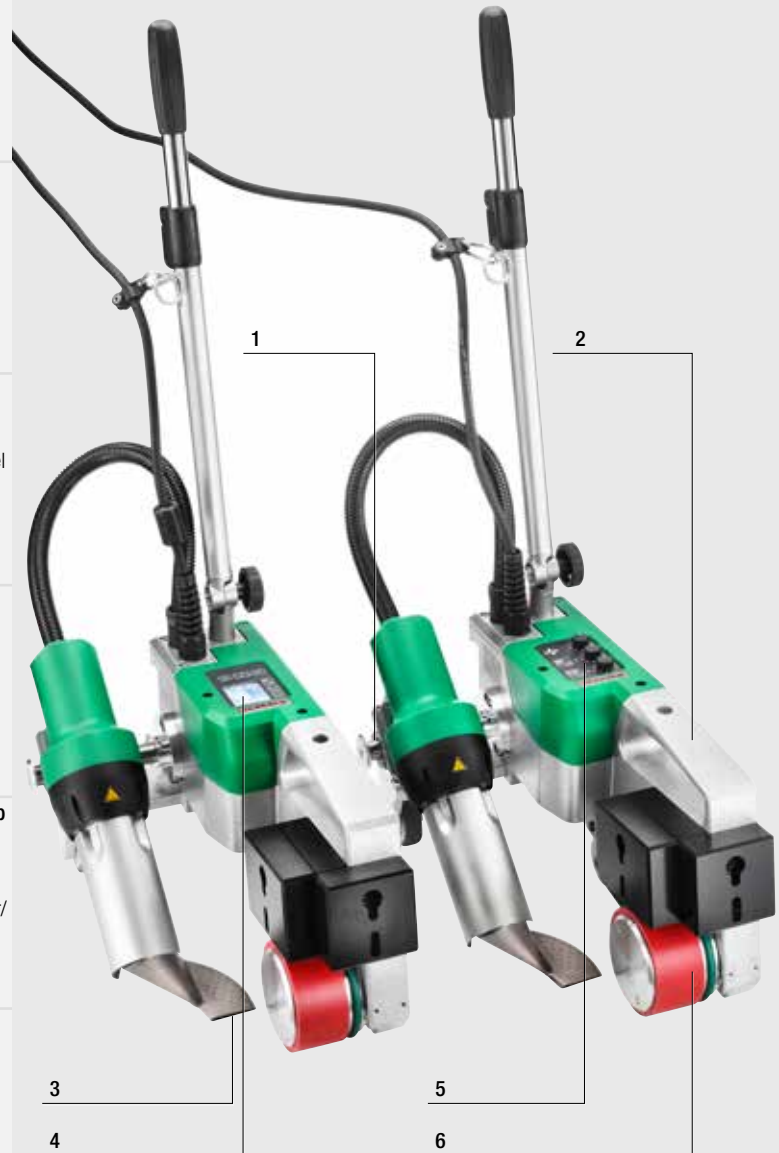

With 3450 W performance, 230 V and 15 Amps in the box, the UNIROOF AT/ST offers speedy top performance on any roof.



Thanks to its ultra slim design, the UNIROOF welds effortlessly even in areas which are narrow and difficult to access.

Hot-air welder

UNIROOF AT



- No retooling, thanks to movable transportation axle
- Maintenance-free direct drive and closed-loop technology
- Ergonomic handling, flexible relocating and optimal machine guiding
- 66% higher welding performance compared to similar machines
- Welding roof structure profiles

Hot-air welder

UNIROOF ST



- No retooling, thanks to movable transportation axle
- Maintenance-free direct drive and open-loop technology
- Ergonomic handling, flexible relocating and optimal machine guiding
- 38% higher welding performance compared to similar machines
- Welding roof structure profiles

















Technical Data	UNIROOF AT	
Voltage	V~	100 / 220 – 240
Frequenz	Hz	50/60
Power	W	1500 / 3450
Temperature, stepless	°C	100 – 620
Air flow range	%	45 – 100
Drive speed, stepless	m/min	1.0 – 10.0
Size (L × B × H)	mm	475 × 244 × 260
Weight	kg	17.5 (incl. 3 additional weights)
Materials	PP, PVC, TPO, ECB, EPDM, EVA, FPO, PO, PIB (other materials upon request)	
Conformity mark	CE	
Protection class I	⊕	
Fan	maintenance-free	
Operation	Digital with display	
Temperature control	Closed-loop System	

Article No.:		
153.598	UNIROOF AT, 220 – 240 V/3450 W, 40 mm, with Euro-plug	
153.599	UNIROOF AT, 120 V/1800 W, 40 mm (1.6 inch), with US-plug	
157.188	UNIROOF AT, 220 – 240 V/3450 W, 30 mm, with Euro-plug	
166.368	UNIROOF AT, 220 – 240 V/3450 W, 40 mm, with Korea plug	

Technical Data	UNIROOF ST	
Voltage	V~	100 / 220 – 240
Frequenz	Hz	50/60
Power	W	1500 / 3450
Temperature, stepless	°C	100 – 620
Air flow range	%	45 – 100
Drive speed, stepless	m/min	1.0 – 10.0
Size (L × B × H)	mm	475 × 244 × 260
Weight	kg	17.5 (incl. 3 additional weights)
Materials	PP, PVC, TPO, ECB, EPDM, EVA, FPO, PO, PIB (other materials upon request)	
Conformity mark	CE	
Protection class I	⊕	
Fan	brush motor	
Operation	Potentiometer	
Temperature control	Open-loop System	

Article No.:		
153.600	UNIROOF ST, 220 – 240 V/3450 W, 40 mm, with Euro-plug	
157.189	UNIROOF ST, 220 – 240 V/3450 W, 30 mm, with Euro-plug	
153.601	UNIROOF ST, 120 V/1800 W, 40 mm (1.6 inch), with US-plug	

Accessories UNIROOF AT/ST

	155.414 Roof structure profile kit		108.129 T-shape guide bar upper part
	155.325 Grip-nozzle 40 mm		156.446 UNIROOF AT/ST 80 mm bitumen kit
	149.597 spring plate		
	152.742 Additional weight, front 1.5 kg		155.473 Heating element 230 V / 3300 W 153.947 Heating element 120 V / 1800 W 154.231 Heating element 100 V / 1500 W 145.604 Heating element 120 V / 2300 W* * Suitable for undervoltage so that the temperature can be reached
	152.741 Additional weight, lateral 2.0 kg		
	154.462 Nozzle calibration device		
	132.429 2 welding plates for optimum welding start		
	138.817 Steelbrush to clean nozzle		
	154.522 Transportation axle 300 mm		
	152.706 Transportation axle 220 mm for radius welding		
	154.827 Storage case UNIROOF		
	155.577 Locking plate for additional weights		
	137.843 T-shape guide bar		

versatile, easy to maintain, efficient.



VARIMAT V2: Fast and dependable.

Using the new VARIMAT V2, polymer roofing membranes can be welded more rapidly resulting in lower cost. Users appreciate its streamlined ergonomics and its ease of use. The clearly laid out operating unit's "e-Drive" allows for the control of all relevant weld parameters.



Highly reliable in application even at undervoltage.

Hot-air welder

VARIMAT V2



- Process reliability: Machine cuts out if undervoltage is too high
- Patented spherical roller compensates unevenness
- Guide bar for ergonomic handling
- Maintenance free blower means lower service costs
- User-friendly display with "e-Drive" (press and turn control) to recall preset and saved welding settings
- Constant drive with regulated electronics





Technical data

Voltage	V~	230 / 400
Power	W	3680 / 5700
Temperature	°C	100 – 600
Speed	m/min	0.7 – 12
Air flow range	%	50 – 100
Width of welding nozzle	mm	40
Size (L x W x H)	mm	640 x 430 x 330
Weight	kg	35
Conformity mark	CE	
Protection class I	⊕	

Article No.:

- 138.108 VARIMAT V2, 230 V / 3680 W, Euro plug, storage case
- 137.821 VARIMAT V2, 400 V / 5700 W, 16 A CEE-plug, storage case
- 141.572 VARIMAT V2, 230 V / 3680 W, with 80 mm nozzle for bitumen, Euro plug, device case
- 153.428 VARIMAT S, 230 V / 4600 W, Euro-plug
- 153.427 VARIMAT S, 400 V / 5700 W, CEE-plug

Accessories VARIMAT V2

1		Ergonomic Height and angle of guide-bar can be adjusted easily
2		Maintenance-free High performance and brushless blower motor, no brushes to change
3		Intuitive Protected design. Easy-to-view display with "e-drive" and easy-to-store welding settings
4		Weld seam control The green air dam belt keeps the hot air in the welded seam. High speed New welding nozzle with protected design for reliable welding quality
5		More stability The patented pressure roller smoothes out any unevenness

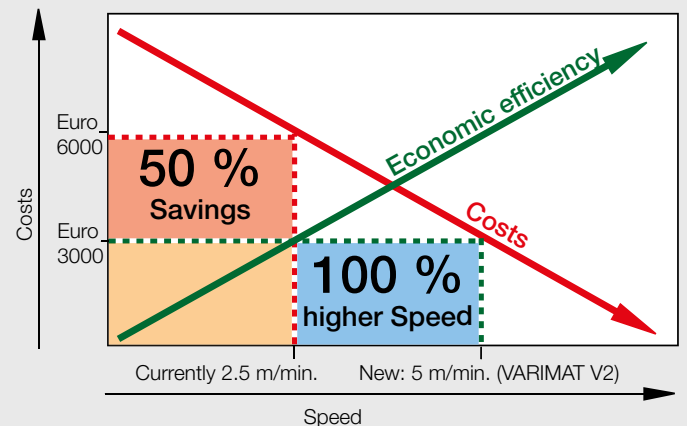





Welded with standard nozzle.



Welded with grip nozzle 25% higher weld seam strength. Mainly for TPO sealing sheets.

	113.995 Grip-nozzle 30 mm for TPO / FPO single plies
	113.600 Grip-nozzle 40 mm for TPO / FPO single plies
	110.805 20 mm overlap welding nozzle for thermoplastic sealing sheeting
	107.067 Additional weight for even more pressure
	139.048 Sturdy storage case 720 × 470 × 450 mm plywood, green included with purchase
	107.649 Replacement rolls
	132.429 2 welding plates for optimum welding start included with purchase
	138.817 Steel brush to clean nozzle included with purchase
	146.514 Solar profile kit for Renolit
	143.162 Gentle pressure roller for difficult ground conditions
	119.111 Chuck cone for replacing silicone pressure roller
	151.530 Mirror welding kit, nozzle right, for special welding applications
	107.612 Heating elements 230 V / 4400 W
	107.613 400 V / 5500 W

	143.179 Complete set with rake nozzle, 40 mm, and pressure roller, soft, 40 mm Rake nozzle to solve the problems caused by bubbles forming on hard surfaces.
	116.323 Rake nozzle, 40 mm
	143.163 Pressure roller, soft, 40 mm (silicone only)
	108.923 Welding unit bitumen-kit 80 mm, 230 V
	108.924 Welding unit bitumen-kit 100 mm, 230 V
	108.925 Welding unit bitumen-kit 120 mm, 230 V
	108.927 Welding unit bitumen-kit 100 mm, 400 V / 6100 W
	108.928 Welding unit bitumen-kit 120 mm, 400 V / 6100 W
	115.892 Welding unit bitumen-kit 80 mm, 400 V / 6100 W
	159.408 Nozzle positioning gauge VARIMAT V2

BITUMAT B2: The flameless.

Welding of modified bitumen sheeting (SBS, APP) with the flameless BITUMAT B2 is much safer than welding with an open flame. The weld strength is significantly better and the single step process makes welding more economical.



Easy unit guidance and clean working with the BITUMAT B2.

Hot-air welder

BITUMAT B2

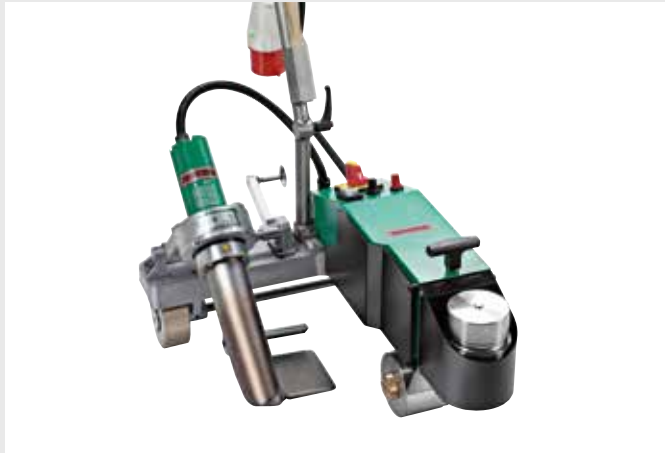

- Flameless welding of modified bitumen
- No shrinking of the insulation due to integrated air dam
- Uniform welding results
- High working speed
- Requires only one user to efficiently weld seams (torch welding requires two)











Technical data

Voltage	V~	230 / 400
Power	W	6700 / 6700
Temperature	°C	20 – 650
Speed	m/min	0.8 – 12
Air flow range	%	85 – 100
Welding nozzle width	mm	75 / 100 / 120
Size (L x W x H)	mm	690 x 490 x 330
Weight	kg	40 (with cable)
Conformity mark		CE
Approval mark		Ⓢ
Protection class I		Ⓢ

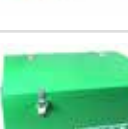
Article No.:

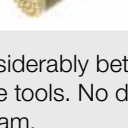
- 140.438 BITUMAT B2 400 V / 6700 W, 75 mm, 16 A-CEE-plug
 - 140.437 BITUMAT B2 400 V / 6700 W, 100 mm, 16 A-CEE-plug
 - 140.436 BITUMAT B2 230 V / 6700 W, 75 mm, 32 A-CEE-plug
 - 138.386 BITUMAT B2 230 V / 6700 W, 100 mm, 32 A-CEE-plug
- Additional versions available upon request.

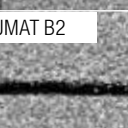
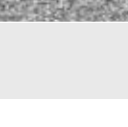
Accessories BITUMAT B2

	138.048	75 mm bitumen nozzle
	138.047	100 mm bitumen nozzle
	137.895	100 mm pressure roller with gap
	137.896	75 mm pressure roller with gap
	140.229	100 mm pressure roller without gap
	140.228	75 mm pressure roller without gap
	156.447	80 mm silicon pressure roller
	158.222	100 mm silicon pressure roller
	140.476	Lifting device
	155.328	BITUMAT B2 120 mm bitumen kit
	140.489	Sturdy storage case, 750 x 555 x 450 mm (included with purchase)
	126.594	Heating elements 400 V / 6500 W
	126.386	230 V / 6500 W

Considerably better welding results when compared with open flame tools. No damage to insulating material due to integrated air dam.

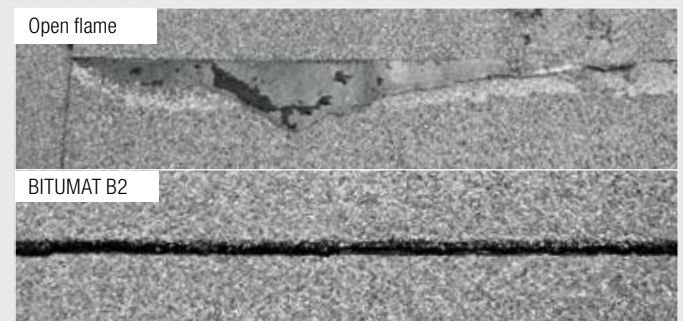

EXAMO: The inspector.

Is your seam sealed? Can it withstand the specified peel, tensile and shear forces? EXAMO performs tests at the construction site – quick, reliable and uncomplicated.

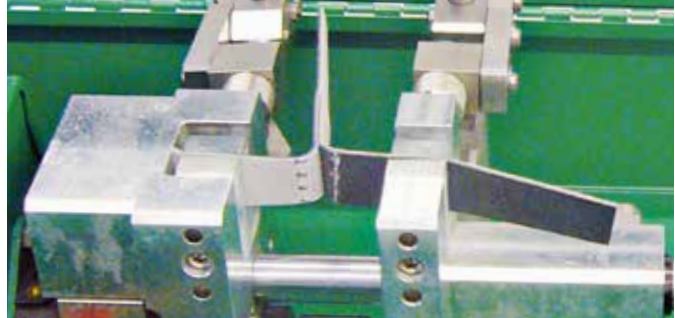

Testing a weld seam with the EXAMO USB.

Tensiometer

EXAMO 300F USB, 600F USB



- Construction-site approved
- Handy, robust and reliable
- Testing of elongation, peak force, tear force, test speed and position
- With jaws also suitable for geo textiles (see accessories)
- Electronic recording of the measurement data

Technical Data			
Type		300F USB	600F USB
Voltage	V~	230	230
Power	W	200	200
Tensile load	N	4000	4000
Jaw spacing	mm	5 – 300	5 – 600
Range	mm	300	600
Test speed	mm/min	20 – 550	20 – 550
Sample thickness	mm	max. 7	max. 7
Sample width	mm	max. 40 (60 optional)	max. 40 (60 optional)
Size (L x W x H)	mm	750 x 270 x 190 (case)	1050 x 270 x 190 (case)
Weight	kg	14	17.5
Conformity mark		CE	CE
Protection class I		⊕	⊕

Article No.:

- 139.059 EXAMO 300F USB, 230 V / 200 W, incl. USB memory stick, Euro plug
 139.060 EXAMO 600F USB, 230 V / 200 W, incl. USB memory stick, Euro plug

Accessories EXAMO 300F USB, 600F USB

	134.832 Testing and calibration kit to test and calibrate your EXAMO USB
	108.185 Jaw kit 60 mm for geotextiles including two pairs of jaws
	144.416 USB memory-stick

Leister offers a service to create a welding window. With new sealing sheets in particular, it is important to have the right starting parameters.

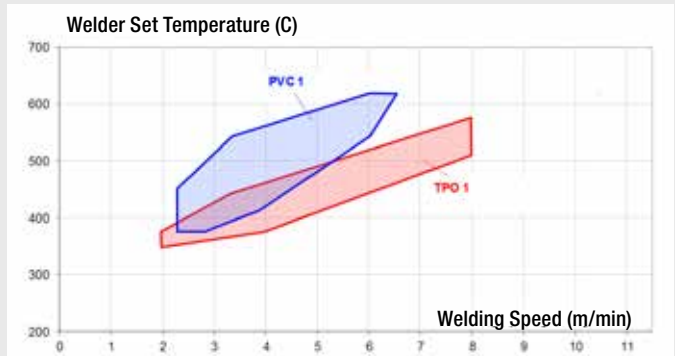

Typical welding windows for TPO and PVC



For testing T-joints

Article No.:

- 153.026 VACUUM BELL Ø 320 mm
 153.024 VACUUM PUMP 230V
 153.025 VACUUM PUMP 120V

TRIAC ST – Design meets experience

The new TRIAC ST from Leister is primarily used for welding and plastic fabrication. During its development, a deliberate choice was made to do without extra technical features. Instead it is distinguished by comfort, being reliable versatile, robust and user friendly, like its predecessor the TRIAC S. A prominent feature here is the two-component handle, which is not only attractive, but also gives the user perfect grip. The low weight of less than 1 kg/2.18 lbs ensures a perfect weight balance.

Product advantage



1
Ergonomic handling:
 The 2-component handle and perfect tool balance ensure ideal grip and optimum working even under the toughest conditions.

Perfect weight:
 Weighing less than 1 kg, the TRIAC ST is even lighter than its predecessor.



2
Always keeps a cool head:
 There is an actively cooled protective tube for greater work safety.



3
Welding capacity:
 Thanks to optimized high-roughness, the TRIAC ST guarantees high welding performance.

2



4
Reliability:
 A new temperature management and the high resistance to dust enable a long service life of the heating elements.



5
Swiss thoroughness:
 The air filters, located on either side, can easily be removed and cleaned. This ensures optimum air flow and maximum power output.

Best protection:
 The filters provide effective protection against moisture and dust.

TRIAC AT: Robust and intelligent.

The TRIAC AT is an intelligent hot-air hand tool for welding and shrinking plastics that is suitable for on-site use. It is designed for the needs of even the most demanding professional. Every tool undergoes stringent quality checks prior to leaving the factory in Switzerland. This high-quality hot-air hand tool is equipped for all situations. Its universal areas of application are virtually unlimited. The TRIAC AT will continue to prove its merit in any weather condition and is just as effective outside as it is indoors – all during continuous operation.

Hot-air hand tool

TRIAC ST



- Suitable for the work site
- Functional design: two-component handle grip and optimum center of gravity ensure good ergonomics
- Quick clean air filters
- Automatic carbon stop and heating element protection provide automatic protective measures

Technical data		
Voltage	V~	120 / 230
Frequency	Hz	50 / 60
Power	W	1600 / 1600
Temperature	°C	40 – 700
Air volume (20°C)	l/min	240 (500 at max. temp)
Dynamic pressure	Pa	3000
Ø Nozzle holder	mm	31.5
Emission	dB(A)	67
Size (L × Ø)	mm	338 × 90, handle Ø 56
Weight	kg	<1 (without power cord)
Conformity mark	CE	
Approval mark		
Protection class II		
Article No.:		
141.308	TRIAC ST, 120 V / 1600 W for push-fit nozzles with UK-plug	
141.309	TRIAC ST, 230 V / 1600 W for push-fit nozzles with UK-plug	
141.311	TRIAC ST, 230 V / 1600 W for push-fit nozzles with CH plug	
141.227	TRIAC ST, 230 V / 1600 W for push-fit nozzles with Euro plug	
144.013	TRIAC ST, 230 V / 1600 W for screw-on nozzles with Euro plug	
153.891	TRIAC ST, 220 V / 1600 W for push-fit nozzles with KR-plug	

Hot-air hand tool

TRIAC AT











- Suitable for the work site
- Closed loop controlled temperature
- Open loop controlled air volume
- Intelligent «e-Drive» operating unit
- Ergonomic handling
- Modern design

Technical data		
Voltage	V~	120 / 230
Frequency	Hz	50 / 60
Power	W	1600 / 1600
Temperature	°C	40 – 620
Air volume (20°C)	l/min	160 – 240 (500 at max. temp)
Dynamic pressure	Pa	1600 – 3000
Ø Nozzle holder	mm	31.5
Emission	dB(A)	67
Size (L × Ø)	mm	338 × 90, handle Ø 56
Weight	kg	1 (without power cord)
Conformity mark	CE	
Approval mark		
Protection class II		
Article No.:		
141.319	TRIAC AT, 120 V / 1600 W, with UK-plug	
141.320	TRIAC AT, 230 V / 1600 W, with UK-plug	
141.314	TRIAC AT, 230 V / 1600 W, with Euro-plug	
141.322	TRIAC AT, 230 V / 1600 W, with CH-plug	
142.737	TRIAC AT, 230 V / 1600 W for screw-on nozzles with Euro plug	
148.005	TRIAC AT, 220 V / 1600 W, for push-fit nozzles with KR-plug	



Lap welding made easy.

Accessories TRIAC ST / TRIAC AT

	<p>Wide slot nozzle, push-fit 107.123 20 mm, angled 107.132 40 mm, standard nozzle 107.133 40 mm, perforated 107.129 60 mm for bitumen 107.131 80 mm for bitumen</p> <p>(more: www.leister.com "downloads")</p>		<p>107.124 20 mm angled nozzle, 90°, push-fit</p>
	<p>Wide slot nozzle 105.475 20 mm, straight 105.485 25 mm, straight 105.494 30 mm, angled</p>		<p>107.130 Wide slot nozzle 40mm, 60° bent 107.125 20 mm angled nozzle, 60°, push-fit, for right hander 105.503 20 mm angled nozzle, 60°, push-fit</p>
	<p>105.487 Wide slot nozzle 20 mm, curved and angular, with clamping angle inwards</p>		<p>106.991 5 mm speed weld nozzle, push-fit on Ø 5 mm tubular nozzle</p>
	<p>100.303 Ø 5 mm, tubular nozzle, push-fit 105.575 Ø 5 x 100 mm, tubular nozzle, push-fit 106.982 Ø 5 x 150 mm, extension nozzle, push-fit</p>	<p>5</p> 	
	<p>105.576 tubular nozzle Ø 5 mm, 90° curved</p>		



Essential working device. The TRIAC is a partner you can rely on for detail work.



ELECTRON ST – Strong, compact and handy

The new ELECTRON ST is a real powerhouse among Leister's hand tools. The appearance of this tool has been modeled after the new TRIAC range. For the user, this means improved ergonomics and, as a result, the ability to work in more comfort. Existing ELECTRON nozzles fit the new model.

Product advantages



Powerful:
Suitable for any application thanks to its outstanding power rating of up to 3400 W.



Perfekte Ergonomie:
100 lighter and with a 2-component handle that's nearly 8 mm slimmer than its predecessor.



Infinitely adjustable:
Easy air temperature adjustment up to 650 °C.

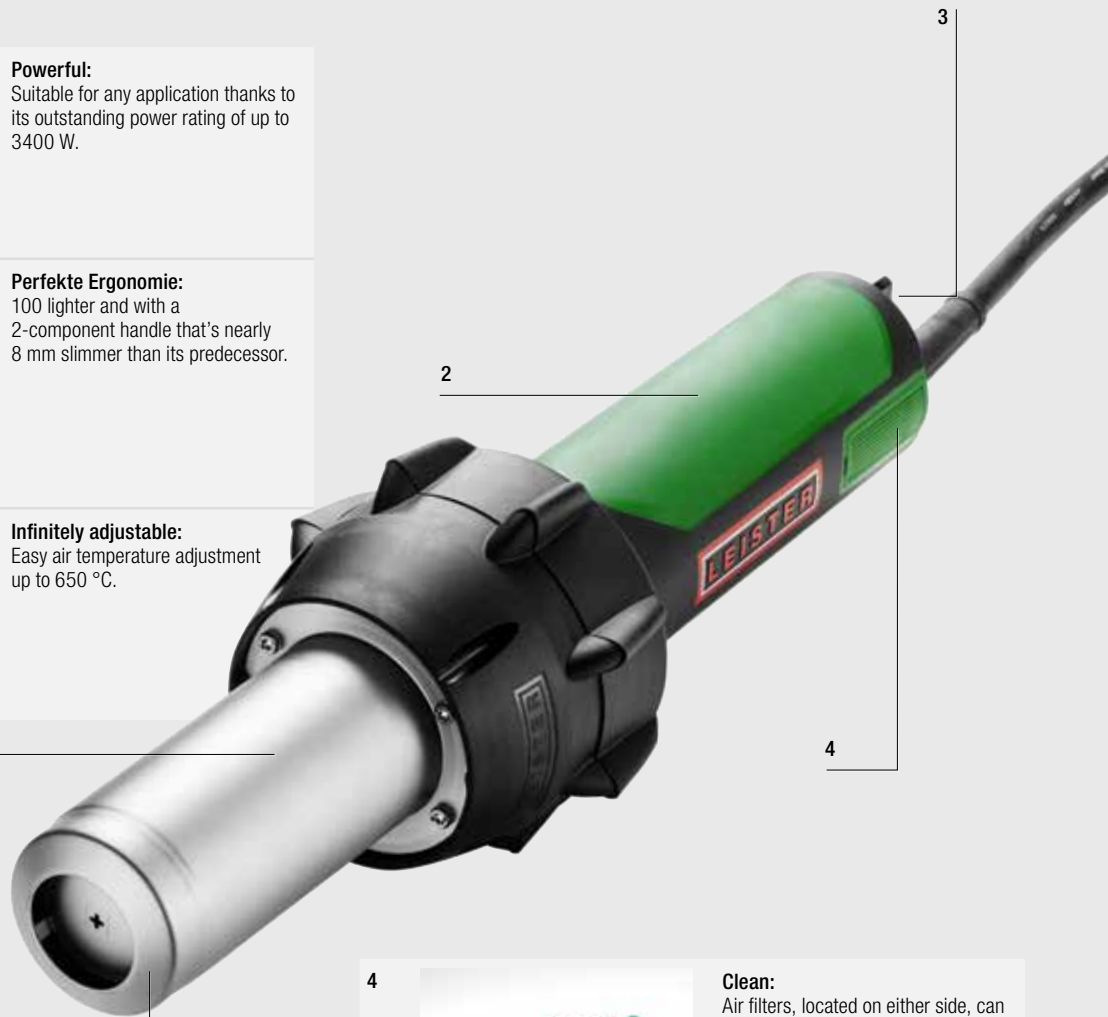

Clean:
Air filters, located on either side, can be removed and cleaned in no time at all.



Compatible:
All predecessor nozzles fit the ELECTRON ST.



Work safely with hot air.

Hot-air hand tool

ELECTRON ST



- Suitable for construction sites
- Leister's most powerful hand tool
- Easy-clean air filter
- Carbon stop and heating element protection provide automatic protective measures
- Sturdy tool case supplied

Technical data

Voltage	V~	230 / 230 / 200 / 120
Frequency	Hz	50 / 60
Power	W	2300 / 3400 / 3000 / 2400
Temperature	°C	40 – 650
Air volume (20°C)	l/min	360 (700 at max. temp)
Dynamic pressure	Pa	3400
Ø Nozzle holder	mm	50
Emission	dB(A)	67
Size (L × Ø)	mm	338 × 90, handle Ø 56
Weight	kg	1.1 (without power cord)
Conformity mark	CE	
Approval mark		
Protection class II		

Article No.

145.567	ELECTRON ST, 230 V / 3400 W for push-fit nozzles with Euro plug
149.673	ELECTRON ST, 230 V / 2300 W for push-fit nozzles with Euro plug
145.563	ELECTRON ST, 120 V / 2400 W for push-fit nozzles with UK plug
145.568	ELECTRON ST, 230 V / 3400 W for push-fit nozzles with UK plug
154.839	ELECTRON ST, 220 V / 3400 W for push-fit nozzles with KR-plug

Accessories ELECTRON ST

	107.258	Wide slot nozzle, push-fit 70 × 10 mm, for bitumen
	107.653	Wide slot nozzle 75 × 2 mm, push-fit
	151.068	Tool stand for 107.653
	107.270	Wide slot nozzle 150 × 12 mm, push-fit
	142.281	Scraper nozzle
	145.606 149.675 145.604	Heating elements 230 V / 3300 W 230 V / 2200 W 120 V / 2300 W

HOT JET S: Small and powerful.

As the most compact hot-air hand tool from Leister, the HOT JET S' low weight of 600 grams (including cord and slim handle) ensures high-powered, fatigue-free welding.

Hot-air hand tool

HOT JET S



- The smallest Leister hot-air hand tool
- Stepless, electronically controlled temperature
- Stepless, electronically controlled air flow
- Low noise
- Flexible, integrated tool stand

Accessories HOT JET S

	107.141 15 mm wide slot nozzle, push-fit
	107.142 20 mm wide slot nozzle, push-fit
	105.549 10 x 2 mm wide slot nozzle
	107.144 Ø 5 mm tubular nozzle, push-fit
	105.556 20 mm angled nozzle, 70° angled, push-fit
	106.989 3 mm speed welding nozzle, push-fit on Ø 5 mm tubular nozzle
	106.990 4 mm speed welding nozzle, push-fit on Ø 5 mm tubular nozzle
	106.991 5 mm speed welding nozzle, push-fit on Ø 5 mm tubular nozzle

Technical data

Voltage	V~	120 / 230
Frequency	Hz	50 / 60
Power	W	460 / 460
Temperature	°C	40 – 600
Air volume (20°C)	l/min	40 – 110 (200 at max. temp)
Pressure static	Pa	230 – 1600
Ø Nozzle holder	mm	21.3
Emission	dB(A)	59
Size (L x Ø)	mm	235 x 70, handle Ø 40
Weight	kg	0.4 (without power cord)
Conformity mark	CE	
Approval mark		
Protection class II		

Article No.:

100.648	HOT JET S, 230 V / 460 W, with Euro plug
100.862	HOT JET S, 120 V / 460 W, without plug
100.854	HOT JET S, 230 V / 460 W, with AUS plug
140.030	HOT JET S, 220V/ 460W for push-fit nozzles with KR-plug













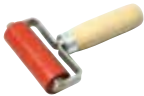

Suitable for complicated details or in tight spaces.



Leister scissors with special serrated edge for complex requirements when cutting plastic sheets.

Hot-air hand tools

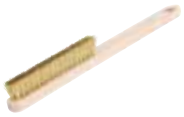
General accessories

	106.974 80 mm silicone pressure roller
	140.160 40 mm silicone pressure roller with ball bearings (silicone)
	140.599 Spare roll for 140.160
	140.161 Pressure roller 28 mm, with ball bearings (silicone)
	140.598 Spare roll for 140.161
	106.976 28 mm pressure roller (PTFE)
	106.972 Brass pressure roller with ball bearings
	138.314 Seam probe tester for overlap seams
	151.188 Chamfer plane for T-joints on
	157.544 Leister Universal scissors 260 mm with special shaft grinding
	159.514 Weld seam test template
	116.798 Brass brush
	107.348 Tool rest for TRIAC AT, TRIAC ST, ELECTRON ST

	137.855 Leister cutter with four spare blades
	138.902 Hooked blade for LEISTER-cutter (10 dispenser with 10 pcs=100 pcs)
	138.539 Straight-edge blade for LEISTER-cutter (10 dispenser with 10 pcs = 100 pcs)
	151.382 Inside corner tool
	116.586 Storage case for TRIAC AT, TRIAC ST, ELECTRON ST
	160.353 Cable cord roller 25 m, with 1 x CEE 400V and 2 x EU socket 230V
	161.152 Cable cord roller 25 m, with 1 x CEE 400 V and 2 x T23 CH socket 230 V
	161.207 Cable cord roller 25 m, with 1 x CEE 400 V and 2 x Typ E with ground pin socket 230 V
	164.048 Cable cord roller 45 m, 4 x 230 V, EU socket
	160.015 Cable extension cord 15 m PUR 5 x 2.5 mm ² , with CEE 400V plug
	159.239 Cable extension cord 15 m PUR 3 x 2.5 mm ² , with EU plug 230V



Kehlfix is the economic tool for efficient working.

More at the new accessories catalog at www.leister.com/accessories

Legal Information

Contents

We take the greatest care in presenting correct, complete and up-to-date information. However, we can assume no responsibility whatsoever for the information offered in this catalog. We reserve the right to modify or update all information at any time without prior notice.

Copyrights and trademarks

All text, images, graphics as well as their arrangement are subject to copyright protection and other laws on the protection of intellectual property. The reproduction, alteration, transmission or publication of this catalog in part or in its entirety, except for personal, non-commercial use, is prohibited in all possible forms.

All the marks featured in this catalog (protected all brand marks, logos and business names) are the property of Leister Technologies AG or third parties and may not be used, permanently downloaded, copied or distributed without prior written consent.

Specifications

Specifications are subject to change at any time without prior notice.

© Copyright by Leister.



Have a look on:

www.youtube.com/user/leisterswitzerland



Like and share us on:

www.facebook.com/leisterworld



Follow us on Twitter:

twitter.com/leisterworld



join us on LinkedIn:

www.linkedin.com/company/leister-technologies-ag





«Leister – the synonym for quality,
innovation and technology. »»

«With strong technical and application competence
Leister provides standard products and custom
engineered solutions to all major industries.»»

«Recognized as the world-wide leader in
developing and producing quality products.»»

«The Leister Group, its employees and distribution
network are committed to be strong and reliable
partners, giving you the opportunity to move your
business forward. »»

«Serving all corners of the globe since 1949,
with representation in over 100 countries we are
local world wide and close to our customers.»»

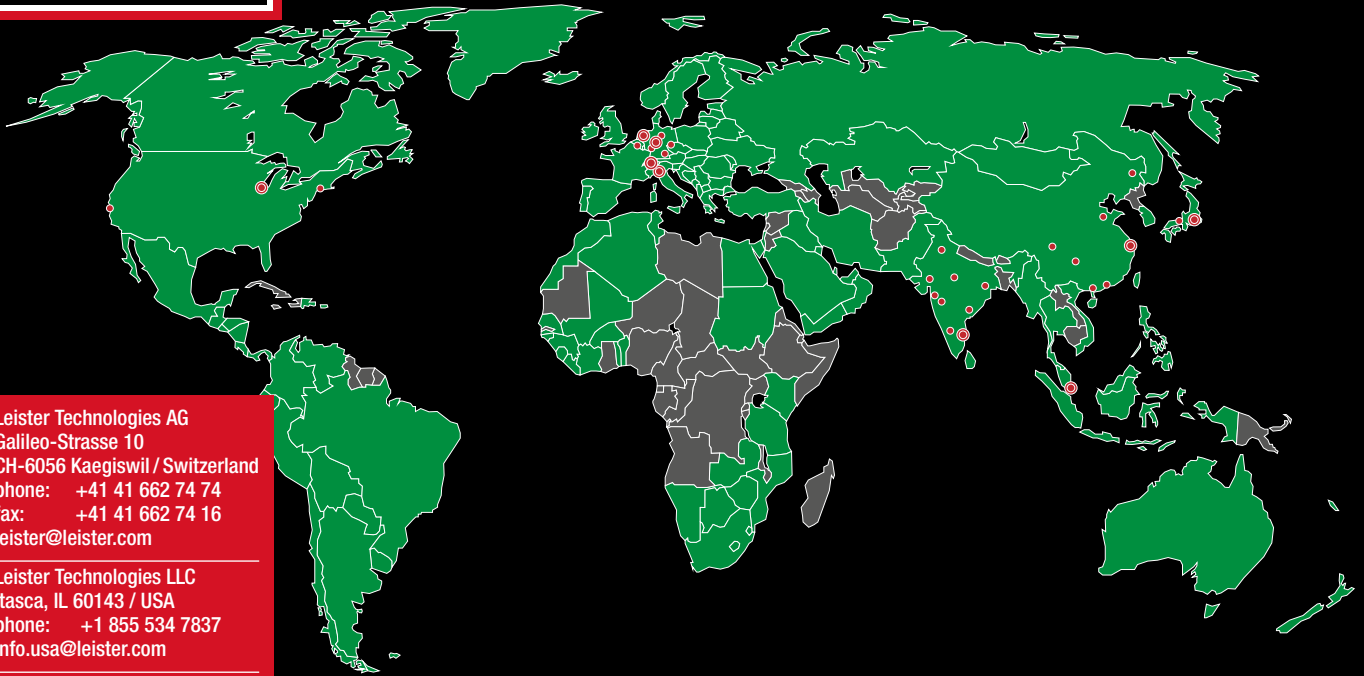

Leister Technologies AG
Galileo-Strasse 10
CH-6056 Kaegiswil / Switzerland
phone: +41 41 662 74 74
fax: +41 41 662 74 16
leister@leister.com

Leister Technologies LLC
Itasca, IL 60143 / USA
phone: +1 855 534 7837
info.usa@leister.com

Leister Technologies Ltd.
Shanghai 201 109 / PRC
phone: +86 21 6442 2398
leister@leister.cn

Leister Technologies KK
Osaka 564-0051 / Japan
phone: +81 6 6310 62 00
sales-japan@leister.com

Leister Technologies Benelux BV
3991 CE Houten / Nederland
phone: +31 (0)30 2199888
info@leister.nl

Leister Technologies Italia s.r.l.
20090 Segrate / Italia
phone: +39 02 2137647
sales@leister.it

Leister Technologies India Pvt
600 041 Chennai / India
phone: +91 44 2454 3436
info@leister.in

Leister Technologies
Deutschland GmbH
D-58093 Hagen / Germany
phone: +49-(0)2331-95940
info.de@leister.com

Our close worldwide network of more than 130 Sales and Service Centres in more than 100 countries.

Europe:	Sweden	Poland	Chile	Africa:	Asia Pacific:
Andorra	Switzerland	Romania	Colombia	Algeria	Bangladesh
Austria	Turkey	Russia	Ecuador	Botswana	Greater China
Belgium	United Kingdom	Serbia	Peru	Egypt	India
Cyprus	Vatican	Slovakia	Venezuela	Ivory Coast	Indonesia
Denmark	Albania	Slovenia		Kenya	Japan
Finland	Armenia	Ukraine		Lesotho	Korea
France	Azerbaijan		Central Asia:	Libya	Malaysia
Germany	Belarus	Americas:	Kazakhstan	Malawi	Mongolia
Greece	Bosnia-Herzegovina	Canada	Kyrgyzstan	Morocco	Philippines
Iceland	Bulgaria	Mexico	Tajikistan	Mozambique	Singapore
Ireland	Croatia	U.S.A.	Turkmenistan	Namibia	Sri Lanka
Italy	Czech Republic	Belize	Uzbekistan	North Sudan	Thailand
Luxembourg	Estonia	Costa Rica		South Africa	Vietnam
Malta	Georgia	El Salvador	Middle East:	Swaziland	
Monaco	Hungary	Guatemala	Bahrain	Tunisia	Oceania:
Netherlands	Kosovo	Honduras	Iran	Zambia	Australia
Norway	Latvia	Nicaragua	Iraq	Zimbabwe	New Zealand
Portugal	Lithuania	Panama	Israel		
Liechtenstein	Macedonia	Argentina	Jordan		
San Marino	Moldova	Bolivia	Qatar		
Spain	Montenegro	Brazil	Saudi Arabia		
			U.A.E		

© Copyright by Leister, Switzerland

Your Leister Sales and Service Center: